

Dimensional drawings continued...

L100 -007MFU2
-007MFR2

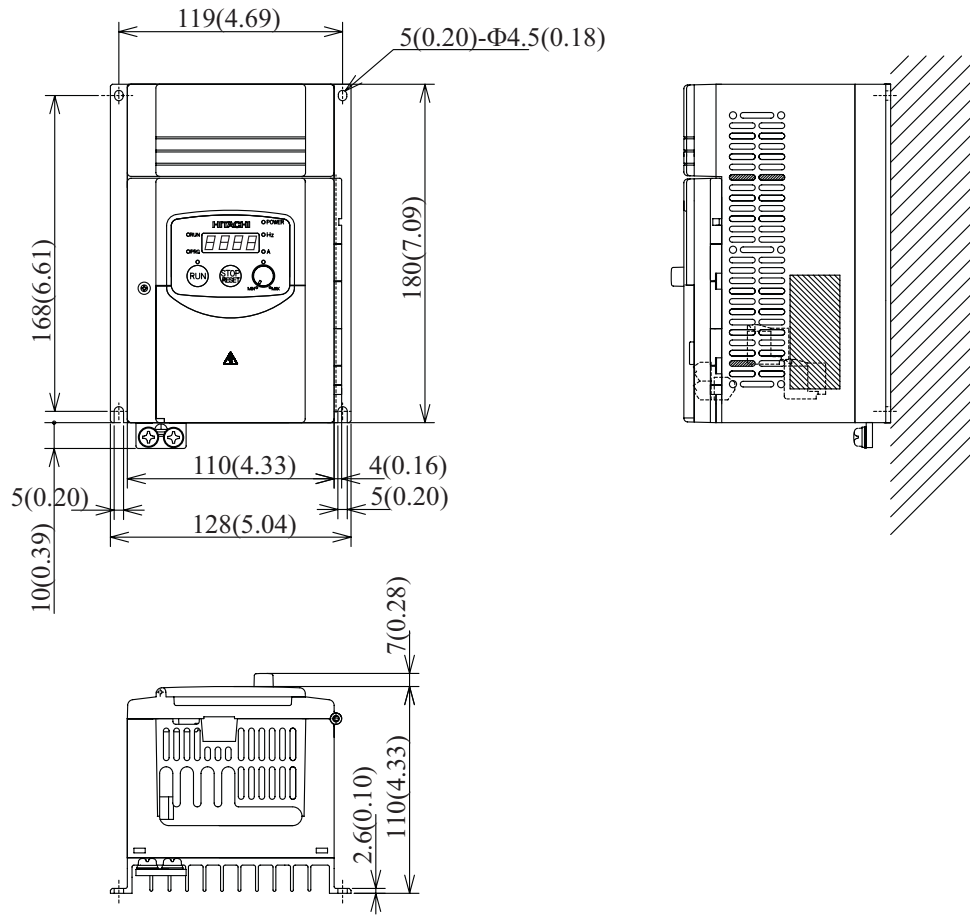

Preparing for Wiring

It is very important to perform the wiring carefully and correctly. Before proceeding, please study the caution and warning messages below.



WARNING: “Use 60/75°C Cu wire only” or equivalent.



WARNING: “Open Type Equipment.”



WARNING: “A Class 2 circuit wired with Class 1 wire” or equivalent.



WARNING: “Suitable for use on a circuit capable of delivering not more than 5,000 rms symmetrical amperes, 120 V maximum.” For models with suffix M (such as 004MFU2).



HIGH VOLTAGE: Be sure to ground the unit. Otherwise, there is a danger of electric shock and/or fire.



HIGH VOLTAGE: Wiring work shall be carried out only by qualified personnel. Otherwise, there is a danger of electric shock and/or fire.



HIGH VOLTAGE: Implement wiring after checking that the power supply is OFF. Otherwise, you may incur electric shock and/or fire.



WARNING: Do not connect wiring to an inverter or operate an inverter that is not mounted according the instructions given in this manual. Otherwise, there is a danger of electric shock and/or injury to personnel.

Determining Wire and Fuse Sizes

The maximum motor currents in your application determines the recommended wire size. The following table gives the wire size in AWG. The “Power Lines” column applies to the inverter input power, output wires to the motor, the earth ground connection, and any system components such as braking resistors and filters. The “Signal Lines” column applies to any wire connecting to the two green 7 and 8-position connectors just inside the front panel half-door.

Motor Output (kW/HP)		Inverter Model	Wiring		Applicable equipment
kW	HP		Power Lines	Signal Lines	Fuse (UL-rated, class J, 600V)
0.2	1/4	L100-002MFU2/MFR2	AWG16 / 1.3 mm ²	18 to 28 AWG / 0.14 to 0.75 mm ² shielded wire (see Note 4)	10A (single ph.)
0.4	1/2	L100-004MFU2/MFR2	Input: AWG14 / 2.1 mm ² Output: AWG16 / 1.3 mm ²		15A (single ph.)
0.75	1	L100-007MFU2/MFR2	Input: AWG12 / 3.3 mm ² Output: AWG16 / 1.3 mm ²		20A (single ph.)

- Note 1:** Field wiring must be made by a UL-listed and CSA-certified closed-loop terminal connector sized for the wire gauge involved. Connector must be fixed by using the crimping tool specified by the connector manufacturer.
- Note 2:** Be sure to consider the capacity of the circuit breaker to be used.
- Note 3:** Be sure to use a larger wire gauge if power line length exceeds 66 ft (20m).
- Note 4:** Use 18 AWG / 0.75 mm² wire for the alarm signal wire ([AL0], [AL1], [AL2] terminals).

The terminal arrangement below corresponds to all L100-M Series inverter models.

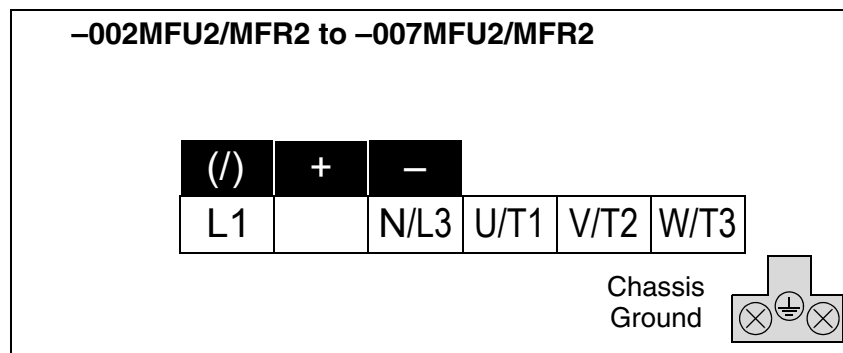

Terminal Dimensions and Torque Specs

The terminal screw dimensions for all L100 inverters are listed in table below. This information is useful in sizing spade lug or ring lug connectors for wire terminations.



CAUTION: Fasten the screws with the specified fastening torque in the table below. Check for any loosening of screws. Otherwise, there is the danger of fire.

Connector	Number of Screw Terminals	Models 002MFU2/MFR2–007MFU2/MFR2	
		Screw Diameter	Width (mm)
Power Terminals	12	M4	9
Control Signal	15	M2	—
Alarm Signal	3	M3	—
Ground Terminals	2	M4	—

When connecting wiring, use the tightening torque listed in the following table to safely attach wiring to the connectors.

Screw	Tightening Torque	Screw	Tightening Torque
M2	0.2 N•m (max. 0.25 N•m)	M4	1.2 N•m (max. 1.3 N•m)
M3	0.5 N•m (max. 0.6 N•m)	M5	2.0 N•m (max. 2.2 N•m)
M3.5	0.8 N•m (max. 0.9 N•m)	—	—

Configuring Drive Parameters

This section provides details for L100-M Series configuration corresponding to Chapter 3, “Configuring Drive Parameters,” in the L100 Inverter Instruction Manual.

Relative to standard L100 Series inverters, Hitachi L100-M Series inverters have additional parameters and functions, or parameters with a different setting range. These include D_16, F_04, B_12, B_13, B_32, C_01 to C_05, C_70, C_71, C_72, and C_79. The tables in this section list only these parameters as they apply to L100-M Series inverters.

“D” Group: Monitoring Functions

L100-M Series inverters add the following to the monitoring functions.

“D” Function			Run Mode Edit	Range and Units
Func. Code	Name / SRW Display	Description		
D_16	Cumulative operation RUN time monitor	Displays total time the inverter has been in RUN mode in hours.	—	0 to 9999 / 1000 to 9999/ 100 to 999 (10,000 to 99,900) hrs.
	RUN 00000000hr			

“F” Group: Main Profile Parameters

For parameter F_04, L100-M Series inverters have the additional “02 Terminal” setting. With F_04=02, the inverters use [FW] and [RV] inputs in real time to determine the direction of rotation for the keypad Run key. For more information on Run key operation and interaction with [FW] and [RV] terminals, see page “Forward Run/Stop and Reverse Run/Stop Commands:” on page 23.

“F” Function			Run Mode Edit	Defaults		
Func. Code	Name / SRW Display	Description		–MFU2	–MFR2	Units
F_04	Keypad Run key routing	Two options; select codes: 00 ...Forward 01 ...Reverse 02 ...Terminal	✘	00	00	—
	INIT DOPE FWD					

“B” Group: Fine Tuning Functions

For the following functions, L100-M Series inverters have new ranges or descriptions.

“B” Function			Run Mode Edit	Defaults		
Func. Code	Name / SRW Display	Description		-MFU2	-MFR2	Units
B_12	Level of electronic thermal setting	Set a level between 5% and 120% for the rated inverter current.	✘	Rated current for each inverter model		%
	E-THM LVL 03.00A					
B_13	Electronic thermal characteristic	Select from three curves, option codes: 00...Reduced torque 01...Constant torque 02...Reduced torque 2	✘	01	00	—
	E-THM CHAR CRT					



NOTE: The set value links with the detection current of output current monitor, electric thermal protection, and overload limit.

The three available electronic thermal characteristic curves are shown in the graph below.

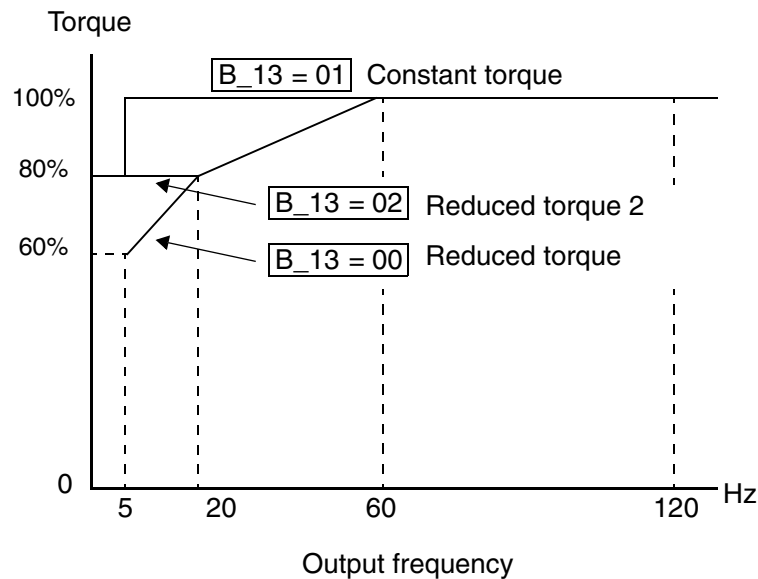

WARNING: When parameter B_12, level of electronic thermal setting, is set to device FLA rating (Full Load Ampere nameplate rating), the device provides solid state motor overload protection at 115% of device FLA or equivalent. Parameter B_12, level of electronic thermal setting, is a variable parameter.

"B" Function			Run Mode Edit	Defaults		
Func. Code	Name / SRW Display	Description		-MFU2	-MFR2	Units
B_32	Reactive current setting	Calibrate detection of motor's no load (reactive current) to improve D_02 display accuracy, range is 0 to 32 Amperes	✓	40% rated current	A	
	IO 0.00A					

B_32: Reactive current setting – The inverter's D_02 monitor function displays the motor current. The display accuracy is normally $\pm 20\%$, provided that the following conditions exist:

- A single motor with standard frame size and characteristics is connected
- The inverter's output frequency is at 50% or higher of the maximum output frequency
- The inverter's output current is within the rated current

However, it will be necessary to calibrate the display accuracy via B_32 adjustment of the internal no-load reactive motor current if any of these conditions exist:

- The motor is smaller than the standard maximum recommended for the inverter
- The motor is a two-pole motor type
- Two or more motors are connected in parallel to the inverter (be sure to multiply the current by the number of motors when setting B_32)

For general purpose motors that have an undetermined internal no-load (reactive) motor current, use the following table for typical current values. For special motors, consult the manufacturer of your particular motor.

Motor			200V Class	
HP	kW	Poles	at 50 Hz	at 60 Hz
1/8	0.1	4	0.6 A	0.5 A
1/4	0.2	2	0.6 A	0.4 A
		4	0.8 A	0.7 A
—	0.3	4	1.1 A	1.1 A
1/2	0.4	2	1.2 A	0.9 A
		4	1.7 A	1.2 A
		6	1.9 A	1.5 A
1	0.75	2	1.9 A	1.3 A
		4	2.2 A	1.7 A
		6	1.8 A	2.2 A

C” Group: Intelligent Terminal Functions

The intelligent input terminals for L100-M Series inverters have 21 possible option assignments.

“C” Function			Run Mode Edit	Defaults		
Func. Code	Name / SRW Display	Description		-MFU2	-MFR2	Units
C_01	Terminal [1] function	Select function for terminal [1] 21 options (see next section)	✘	00 [FW]	00 [FW]	—
	IN-TM 1 FW					
C_02	Terminal [2] function	Select function for terminal [2] 21 options (see next section)	✘	01 [RV]	01 [RV]	—
	IN-TM 2 RV					
C_03	Terminal [3] function	Select function for terminal [3] 21 options (see next section)	✘	16 [AT]	02 [CF1]	—
	IN-TM 3 AT					
C_04	Terminal [4] function	Select function for terminal [4] 21 options (see next section)	✘	13 [USP]	03 [CF2]	—
	IN-TM 4 USP					
C_05	Terminal [5] function	Select function for terminal [5] 21 options (see next section)	✘	18 [RS]	18 [RS]	—
	IN-TM 5 2CH					

L100-M Series inverters have the 15 intelligent input option codes of standard L100 inverters, but with the model series restriction noted below:

Input Function Summary Table				
Option Code	Terminal Symbol	Function Name	Description	
19	PTC	PTC Thermistor Thermal Protection –MFR2 series only	ON	When a thermistor is connected to terminals [5] and [L], the inverter checks for over-temperature and will cause trip event and turn OFF output to motor
			OFF	A disconnect of the thermistor causes a trip event, and the inverter turns OFF the motor

L100-M Series inverters add the following 6 options to the 15 option codes for standard L100 inverter intelligent inputs:

Input Function Summary Table				
Option Code	Terminal Symbol	Function Name	Description	
20	STA	START (3-wire interface)	ON	Starts the motor rotation
			OFF	No change to present motor status
21	STP	STOP (3-wire interface)	ON	Stops the motor rotation
			OFF	No change to present motor status
22	F/R	FWD, REV (3-wire interface)	ON	Selects the direction of motor rotation: ON = FWD. While the motor is rotating, a change of F/R will start a deceleration, followed by a change in direction.
			OFF	Selects the direction of motor rotation: OFF =REV. While the motor is rotating, a change of F/R will start a deceleration, followed by a change in direction.
27	UP	Remote Control UP Function (motor- ized speed pot.)	ON	Accelerates (increases output frequency) motor from current frequency
			OFF	No change to output frequency
28	DWN	Remote Control DOWN Function (motorized speed pot.)	ON	Decelerates (decreases output frequency) motor from current frequency
			OFF	No change to output frequency
31	OPE	Operator Control	ON	Forces the source of the output frequency setting (A_01) and the source of the RUN command (A_02) to be from the digital operator
			OFF	Source of output frequency set by (A_01) and source of run command set by (A_02) is used

The L100-M Series inverters have added the functions below to improve serial communications:

"C" Function			Run Mode Edit	Defaults		
Func. Code	Name / SRW Display	Description		-MFU2	-MFR2	Units
C_70	Data command method	Two option codes: 02...Digital operator 03...RS485	✘	02	02	—
	SELECT REM					
C_71	Communication speed selection	Three option codes: 04...4800 bps 05...9600 bps 06...19200 bps	✘	04	04	bps
	BAU 4800bps					
C_72	Node allocation	Set the address of the inverter on the network. Range is 1 to 32.	✘	01	01	—
	ADDRESS 01					
C_79	Communication error response	Two option codes: 00... Trip 01... Continue operation without tripping	✘	01	01	—
	COM ERR TRP					

Operations and Monitoring

This section covers new or modified intelligent terminal functions for L100-M Series inverters, corresponding to Chapter 4, “Operations and Monitoring,” in the L100 Inverter Instruction Manual. The additional functions include Run key routing via [FW] or [RV] terminals, three-wire operation, remote control up and down functions, and force operation from a digital operator (keypad).

Wiring Diagram Conventions

The input wiring diagrams in this section are examples only. Default and non-default input terminal assignments are noted throughout; your particular assignments may be different. Input switch wiring for -xMFU2 models will connect the switch common (return) to +24VDC, as shown below (left). Input switch wiring for -xMFR2 models will connect the switch common (return) to Logic GND terminal [L], as shown below (right).

Wiring for -MFU2 versions

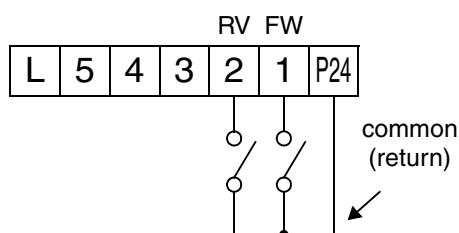

Wiring for -MFR2 versions

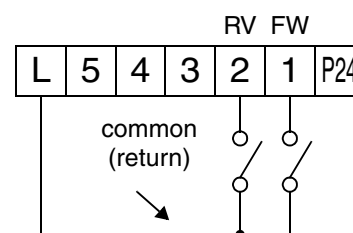

Each wiring example in this section shows both the -xMFU2 and -xMFR2 input wiring *in the same diagram*, as shown to the right. DO NOT connect terminal [P24] to [L]. Be sure the return terminal used matches your inverter type.

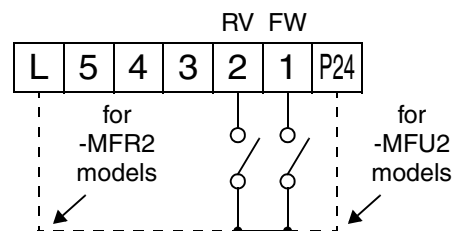

NOTE: The input wiring diagrams in the L100 instruction manual match the -MFU2 models. If your inverter is the -MFR2 type, be sure to wire the inputs as instructed in this addendum.

Waveform Diagram Conventions

The input signal waveform diagrams in this section (and in the L100 manual, Chapter 4) assume the intelligent inputs are *active high* type (corresponds to -MFU2 inverter type). If your inverter is the -MFR2 type, you must invert the ON/OFF logic sense when observing or interpreting the input waveforms.

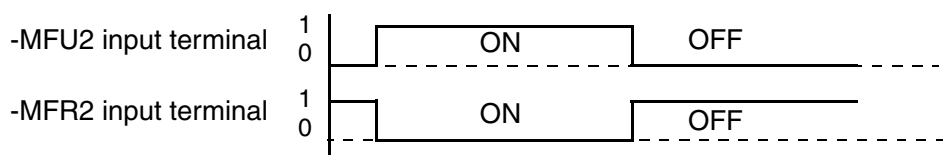

Example Wiring Diagram

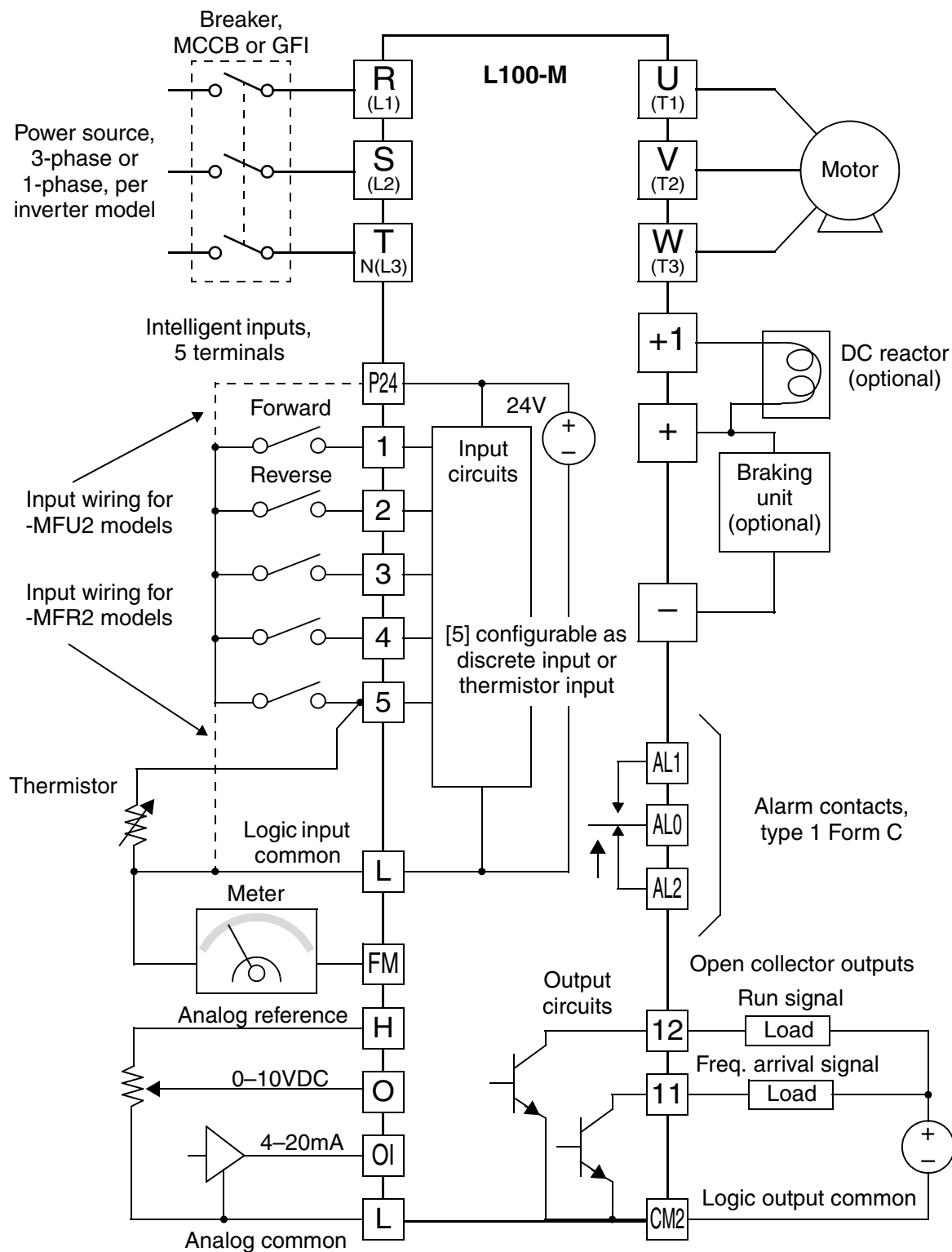

NOTE: For the wiring of intelligent I/O and analog inputs, be sure to use twisted pair / shielded cable. Attach the shield wire for each signal to its respective common terminal at the inverter end only.

Forward Run/Stop and Reverse Run/Stop Commands:

When you input the Run command via the terminal [FW], the inverter executes the Forward Run command (high) or Stop command (low). When you input the Run command via the terminal [RV], the inverter executes the Reverse Run command (high) or Stop command (low).

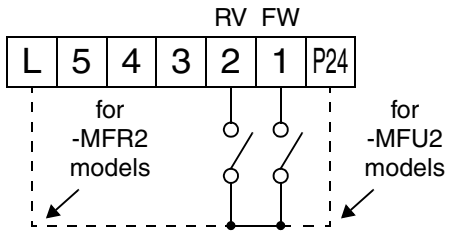
Option Code	Terminal Symbol	Function Name	State	Description
00	FW	Forward Run/Stop	ON	Inverter is in Run Mode, motor runs forward
			OFF	Inverter is in Stop Mode, motor stops
01	RV	Reverse Run/Stop	ON	Inverter is in Run Mode, motor runs reverse
			OFF	Inverter is in Stop Mode, motor stops
Valid for inputs:		C_01, C_02, C_03, C_04, C_05		Example (default input configuration shown—see Chapter 3 in L100 Instruction Manual): 
Required settings:		A_02 = 01 (terminal control) A_02 = 02 (keypad control)		
Notes:				
<ul style="list-style-type: none"> When the Forward Run and Reverse Run commands are active at the same time, the inverter enters the Stop Mode. When a terminal associated with either [FW] or [RV] function is configured for <i>normally closed</i>, the motor starts rotation when that terminal is disconnected or otherwise has no input voltage. 				See I/O specs in the L100 Instruction Manual

L100-M Series inverters can also use [FW] and [RV] inputs in real time to determine the direction of rotation for the keypad Run key. This requires setting A_02=02 (keypad control) and Run Key Routing F_04 = 02 (terminal). The operation is shown below.

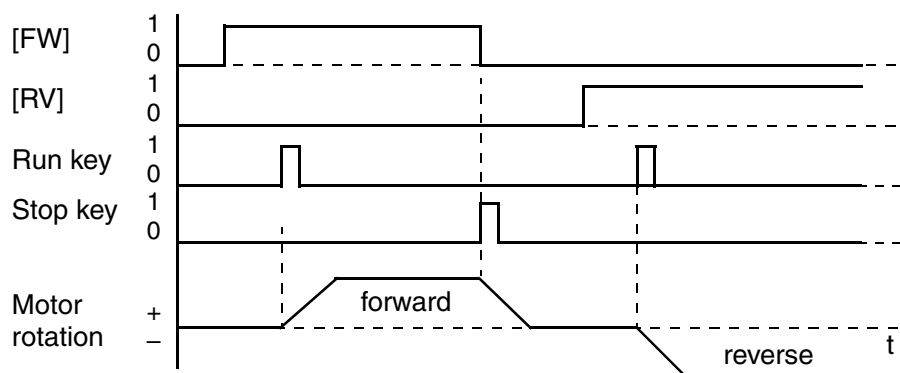

Three-wire Interface Operation

The 3-wire interface is an industry standard motor control interface. This function uses two inputs for momentary contact start/stop control, and a third for selecting forward or reverse direction. To implement the 3-wire interface, assign 20 [STA] (Start), 21 [STP] (Stop), and 22 [F/R] (Forward/Reverse) to three of the intelligent input terminals. Use momentary contact for Start and Stop. Use a selector switch such as SPST for the Forward/Reverse input. Be sure to set the operation command selection A_02=01 for input terminal control of motor. If you have a motor control interface that needs logic-level control (rather than momentary pulse control), use the [FW] and [RV] inputs instead.

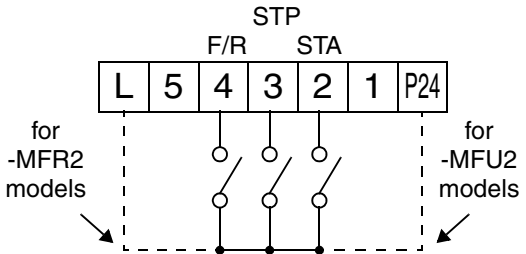
Option Code	Terminal Symbol	Function Name	Input State	Description
20	STA	Start Motor	ON	Start motor rotation on momentary contact (uses acceleration profile)
			OFF	No change to motor operation
21	STP	Stop Motor	ON	No change to motor operation
			OFF	Stop motor rotation on momentary contact (uses deceleration profile)
22	F/R	Forward/Reverse	ON	Select <i>reverse</i> direction of rotation
			OFF	Select <i>forward</i> direction of rotation
Valid for inputs:		C_01, C_02, C_03, C_04, C_05		Example (requires input configuration—see Chapter 3 in L100 Instruction Manual): 
Required settings:		A_02 = 01		
Notes:				
<ul style="list-style-type: none"> The STP logic is inverted. Normally the switch will be closed, so you open the switch to stop. In this way, a broken wire causes the motor to stop automatically (safe design). When you configure the inverter for 3-wire interface control, the [FW] and [RV] intelligent terminal assignments are disabled. The [F/R] terminal signal level is evaluated only when an [STA] pulse occurs. You must assign both the [STA] and [STP] intelligent inputs in order for the three-wire function to work. If you do not assign the [F/R] intelligent input terminal, the three-wire operation will be limited to the forward direction only. 				
				See I/O specs in the L100 Instruction Manual

The diagram below shows the use of 3-wire control. STA (Start Motor) is an edge-sensitive input; an OFF-to-ON transition gives the Start command. The control of direction is level-sensitive, and the direction may be changed at any time. STP (Stop Motor) is also a level-sensitive input, and the Stop signal has priority over the Start signal. Also remember that STP is an active-low signal.

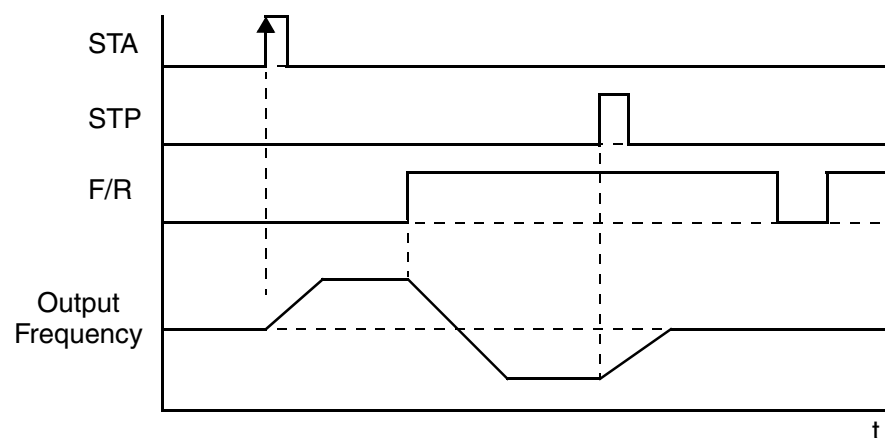

When both STA and STP signals are ON, the STP signal has priority (motor output will be OFF). However, the motor output resumes after STP signal is no longer active if the STA input is still ON.

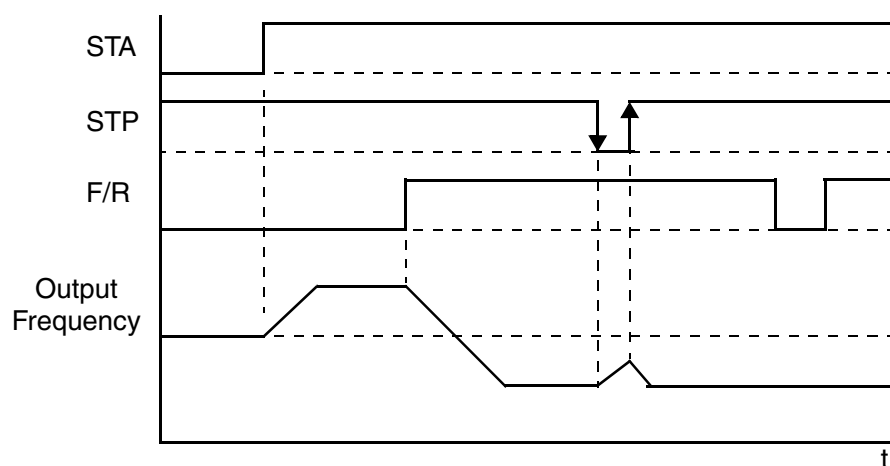

Remote Control Up and Down Functions

The [UP] [DWN] terminal functions can adjust the output frequency for remote control while the motor is running. The acceleration time and deceleration time used with this function is the same as for normal operation ACC1 and DEC1. The input terminals operate as follows:

- Acceleration - When the [UP] contact is turned ON, the output frequency accelerates from the current value. When it is turned OFF, the output frequency maintains its current value.
- Deceleration - When the [DWN] contact is turned ON, the output frequency decelerates from the current value. When it is turned OFF, the output frequency maintains its current value.

In the graph below, the [UP] and [DWN] terminals activate while the Run command remains ON. The output frequency responds to the [UP] and [DWN] commands.

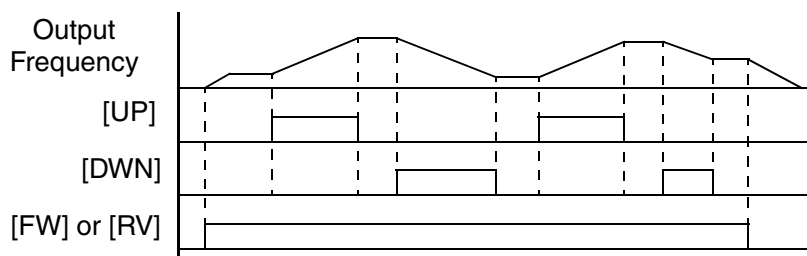

Option Code	Terminal Symbol	Function Name	Input State	Description
27	UP	Remote Control UP Function	ON	Accelerates (increases output frequency) motor from current frequency
			OFF	Output to motor operates normally
28	DWN	Remote Control DOWN Function	ON	Decelerates (decreases output frequency) motor from current frequency
			OFF	Output to motor operates normally
Valid for inputs:		C_01, C_02, C_03, C_04, C_05		Example (requires input configuration—see Chapter 3 in L100 Instruction Manual): <p>for -MFR2 models for -MFU2 models</p>
Required settings:		A_01 = 02		
Notes:				
<ul style="list-style-type: none"> • This feature is available only when the frequency command source is programmed for operator control. Confirm A_01 is set to 02. • This function is not available when [JG] is in use. • The range of output frequency is 0 Hz to the value in A_04 (maximum frequency setting). • The Remote Control Up/Down function varies the inverter speed by directly writing to the F_01 output frequency setting. 				See I/O specs in the L100 Instruction Manual

Force Operation from Digital Operator

This function permits a digital operator interface to override the Run command source setting (A_02) when it is configured for a source other than the operator interface. When the [OPE] terminal is ON and the operator interface gives a Run command, the inverter uses the standard output frequency settings to operate the motor.

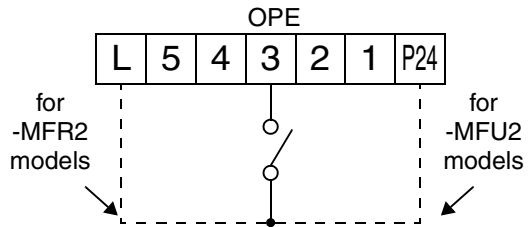
Option Code	Terminal Symbol	Function Name	Input State	Description
31	OPE	Force Operation from Digital Operator	ON	Forces the operator interface Run command to over-ride commands from input terminals (such as [FW], [RV]).
			OFF	Run command operates normally, as configured by A_02
Valid for inputs:		C_01, C_02, C_03, C_04, C_05		Example (requires input configuration—see Chapter 3 in L100 Instruction Manual): 
Required settings:		A_01 A_02 (set not equal to 02)		
Notes:		<ul style="list-style-type: none"> When changing the [OPE] state during Run Mode (inverter is driving the motor), the inverter will stop the motor before the new [OPE] state takes effect. If the [OPE] input turns ON and the digital operator gives a Run command while the inverter is already running, the inverter stops the motor. Then the digital operator can control the motor. 		
				See I/O specs in the L100 Instruction Manual

Inverter System Accessories

This section provides dynamic braking details for L100-M Series configuration corresponding to Chapter 5, “Inverter System Accessories,” in the L100 Inverter Instruction Manual.

Selecting Braking Resistors for External Braking Units

The following tables specify the braking options for L100-M inverters and the braking torque for each option. You can connect a single braking unit to the inverter, or two braking units for additional stopping torque.

Use one BRD-E2 braking unit for the braking torque listed in the following table.

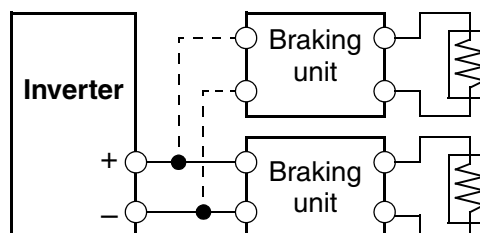

Note the column meanings in the tables:

- Column “A” = Average braking torque from 60 Hz to 3 Hz.
- Column “B” = Average braking torque from 120 Hz to 3 Hz

L100-M Inverter 100V Models			Braking Torque with BRD-E2 Braking Unit									
Model Number	HP	Braking torque without braking unit	Using built-in resistor only		External resistor added							
					HRB1		HRB2		HRB3			
			A	B	A	B	A	B	A	B		
002MFU2/MFR2	1/4	50%	150%	120%								
004MFU2/MFR2	1/2	50%	150%	120%								
007MFU2/MFR2	1	50%	100%	80%	150%	120%						

Connect a second braking unit in parallel for additional braking torque listed in the following table.

L100-M Inverter 100V Models			Braking Torque with TWO (2) BRD-E2 Braking Units									
Model Number	HP	Braking torque without braking unit	Using built-in resistor only		External resistor added							
					HRB1		HRB2		HRB3			
			A	B	A	B	A	B	A	B		
002MFU2/MFR2	1/4	50%	150%	120%								
004MFU2/MFR2	1/2	50%	150%	120%								
007MFU2/MFR2	1	50%	150%	120%								

Troubleshooting and Maintenance

This section provides details for L100-M Series error codes corresponding to Chapter 6, “Troubleshooting and Maintenance,” in the L100 Inverter Instruction Manual.

Error Codes

L100-M Series inverters have the additional error code listed below.

Error Code	Name	Cause(s)
<i>E60</i>	Communication error	<ul style="list-style-type: none">• The RS422/485 serial cable may be disconnected or have an open wire, short, etc.• The communication error may be due to the external device. Check whether the interruption is for more than 3 seconds before resetting the error. If so, the watchdog timer in the inverter is timing out due to no response from the external device.

Drive Parameter Settings Tables

Introduction

This section lists the user-programmable parameters for the L100-M series inverters and the default values, corresponding to Appendix B, “Drive Parameter Settings Tables,” in the L100 Inverter Instruction Manual. The right-most column of the tables is blank, so you can record values you have changed from the default. This involves just a few parameters for most applications. This section presents the parameters in a format oriented toward the keypad on the inverter.

Main Profile Parameters

“F” Group Parameters		Default Setting		User Setting
Func. Code	Name	-MFU2	-MFR2	
F_01	Output frequency setting	0.0	0.0	
F_02	Acceleration (1)	10.0	10.0	
F_03	Deceleration (1)	10.0	10.0	
F_04	Keypad Run key routing	00	00	

Standard Functions

“A” Group Parameters		Default Setting		User Setting
Func. Code	Name	-MFU2	-MFR2	
A_01	Frequency source setting	01	00	
A_02	Run command source setting	01	02	
A_03	Base frequency setting	60.0	60.0	
A_04	Maximum frequency setting	60.0	60.0	
A_11	O-L input active range start frequency	0	0	
A_12	O-L input active range end frequency	0	0	
A_13	O-L input active range start voltage	0	0	
A_14	O-L input active range end voltage	100	100	
A_15	O-L input start frequency enable	01	01	
A_16	External frequency filter time constant	8	8	
A_20	Multi-speed 0 setting	0	0	
A_21	Multi-speed 1 setting	0	5	
A_22	Multi-speed 2 setting	0	10	
A_23	Multi-speed 3 setting	0	15	
A_24	Multi-speed 4 setting	0	20	
A_25	Multi-speed 5 setting	0	30	
A_26	Multi-speed 6 setting	0	40	
A_27	Multi-speed 7 setting	0	50	
A_28	Multi-speed 8 setting	0	60	
A_29	Multi-speed 9 setting	0	0	
A_30	Multi-speed 10 setting	0	0	
A_31	Multi-speed 11 setting	0	0	
A_32	Multi-speed 12 setting	0	0	
A_33	Multi-speed 13 setting	0	0	
A_34	Multi-speed 14 setting	0	0	
A_35	Multi-speed 15 setting	0	0	
A_38	Jog frequency setting	1.0	1.0	
A_39	Jog stop mode	00	00	
A_41	Torque boost method selection	00	00	
A_42	Manual torque boost value	11	11	

“A” Group Parameters		Default Setting		User Setting
Func. Code	Name	-MFU2	-MFR2	
A_43	Manual torque boost frequency adjustment	10.0	10.0	
A_44	V/f characteristic curve selection	00	00	
A_45	V/f gain setting	100	100	
A_51	DC braking enable	00	00	
A_52	DC braking frequency setting	0.5	0.5	
A_53	DC braking wait time	0.0	0.0	
A_54	DC braking force during deceleration	0	0	
A_55	DC braking time during deceleration	0.0	0.0	
A_61	Frequency upper limit setting	0.0	0.0	
A_62	Frequency lower limit setting	0.0	0.0	
A_63, A_65, A_67	Jump (center) frequency setting	0.0	0.0	
A_64, A_66, A_68	Jump (hysteresis) frequency width setting	0.5	0.5	
A_71	PID Enable	00	00	
A_72	PID proportional gain	1.0	1.0	
A_73	PID integral time constant	1.0	1.0	
A_74	PID derivative gain	0.0	0.0	
A_75	PV scale conversion	1.00	1.00	
A_76	PV source setting	00	00	
A_81	AVR function select	02	02	
A_82	AVR voltage select	230/460	200/400	
A_92	Second acceleration time setting	15.0	15.0	
A_93	Second deceleration time setting	15.0	15.0	
A_94	Select method to switch to second accel/decel profile	00	00	
A_95	Acc1 to Acc2 frequency transition point	0.0	0.0	
A_96	Dec1 to Dec2 frequency transition point	0.0	0.0	
A_97	Acceleration curve selection	00	00	
A_98	Deceleration curve selection	00	00	

Fine Tuning Functions

"B" Group Parameters		Default Setting		User Setting
Func. Code	Name	-MFU2	-MFR2	
B_01	Selection of automatic restart mode	00	00	
B_02	Allowable under-voltage power failure time	1.0	1.0	
B_03	Retry wait time before motor restart	1.0	1.0	
B_12	Level of electronic thermal setting	Rated current for each inverter	Rated current for each inverter	
B_13	Electronic thermal characteristic	01	00	
B_21	Overload restriction operation mode	01	01	
B_22	Overload restriction setting	Rated current x 1.25	Rated current x 1.25	
B_23	Deceleration rate at overload restriction	1.0	1.0	
B_31	Software lock mode selection	01	01	
B_32	Reactive current setting	Rated current x 0.40	Rated current x 0.40	
B_81	[FM] terminal analog meter adjustment	80	80	
B_82	Start frequency adjustment	0.5	0.5	
B_83	Carrier frequency setting	5.0	12.0	
B_84	Initialization mode (parameters or trip history)	00	00	
B_85	Country code for initialization	02	00	
B_86	Frequency scaling conversion factor	1.0	1.0	
B_87	STOP key enable	00	00	
B_88	Restart mode after FRS	00	00	
B_89	Data select for digital op. OPE-J	01	01	

Intelligent Terminal Functions

“C” Group Parameters		Default Setting		User Setting
Func. Code	Name	-MFU2	-MFR2	
C_01	Terminal [1] function	00	00	
C_02	Terminal [2] function	01	01	
C_03	Terminal [3] function	16	02	
C_04	Terminal [4] function	13	03	
C_05	Terminal [5] function	18	18	
C_11	Terminal [1] active state	00	00	
C_12	Terminal [2] active state	00	00	
C_13	Terminal [3] active state	00	00	
C_14	Terminal [4] active state	01	00	
C_15	Terminal [5] active state	00	00	
C_21	Terminal [11] function	01	01	
C_22	Terminal [12] function	00	00	
C_23	[FM] signal selection	00	00	
C_31	Terminal [11] active state	00	—	
C_32	Terminal [12] active state	00	—	
C_33	Alarm relay terminal active state	01	01	
C_41	Overload level setting	Inverter rated current	Inverter rated current	
C_42	Frequency arrival setting for accel	0.0	0.0	
C_43	Arrival frequency setting for decel	0.0	0.0	
C_44	PID deviation level setting	3.0	3.0	
C_70	Data command method	02	02	
C_71	Communication speed selection	04	04	
C_72	Node allocation	01	01	
C_79	Communication error response	01	01	
C_91	Debug mode enable	00	00	Do not edit